



# CITY OF CALISTOGA

## STAFF REPORT

**TO:** Honorable Mayor and City Council  
**FROM:** Derek Rayner, Acting Public Works Director/City Engineer  
**DATE:** September 3, 2019  
**SUBJECT:** Consideration of a Resolution Accepting a Donation from Matt Reid for a Memorial Bench and Approving a Budget Adjustment in the Amount of \$2,970.70.

### Approved by

**Michael Kirn, City Manager**

### DESCRIPTION:

Consideration of a Resolution Accepting a Donation from Matt Reid for a Memorial Bench and Approving a Budget Adjustment in the Amount of \$2,970.70.

### RECOMMENDATION:

Consider Adopting a Resolution Accepting a Donation, Approving a Budget Adjustment and Authorizing the Public Works staff to purchase and install the memorial bench at Heather Oaks Park.

### BACKGROUND:

The Public Works Department has received an offer from Matt Reid for a donation in the amount of \$2,970.70, to purchase and install a six-foot memorial bench with an engraved plaque at Heather Oaks Park in memory of his wife Marcy Webb.

6' Cast Bench, Steel Seat, black powder coat	\$1,130.00
Zinc Etched Plaque	350.00
Napa Co Tax	114.70
Freight	389.00
Installation by Public Works Staff	987.00
<b>Total Donation</b>	<b>\$2,970.70</b>

**FINANCIAL IMPACT:**

The acceptance of the donation requires a budget adjustment in the amount of \$2,970.70 to account 01-3289 and the expenditure of the donation to purchase and install the memorial bench from account 01-4123-4401.

**ATTACHMENTS:**

1. Resolution
2. Ross Recreation Quote

**RESOLUTION 2019- XXX**

**RESOLUTION OF THE CITY COUNCIL OF THE CITY OF CALISTOGA,  
COUNTY OF NAPA, STATE OF CALIFORNIA, AUTHORIZING THE  
ACCEPTANCE OF A DONATION FROM MATT REID AND APPROVING A  
BUDGET ADJUSTMENT IN THE AMOUNT OF \$2,970.70**

**WHEREAS**, the Public Works Department has received an offer of a donation in the amount of \$2,970.70 from Matt Reid to purchase and install a six-foot memorial bench at Heather Oaks Park in memory of his wife, Marcy Webb; and

**WHEREAS**, staff has determined that the funds would be sufficient to purchase and install a six-foot memorial bench at Heather Oaks Park; and

**WHEREAS**, the Public Works Department recommends acceptance of the donation and approval of the bench installation.

**NOW, THEREFORE BE IT RESOLVED AS FOLLOWS:**

1. The City Council of the City of Calistoga hereby authorizes the acceptance of a donation in the amount of \$2,970.70 from Matt Reid for the purchase and installation of a six-foot bench at Heather Oaks Park.
2. Approves a budget adjustment in the amount of \$2,970.70 to account 01-3289 and the expenditure of the donation to purchase and install the memorial bench from account 01-4123-4401.

**PASSED, APPROVED, AND ADOPTED** by the City Council of the City of Calistoga at a regular meeting held this **3<sup>rd</sup> day of September 2019**, by the following vote:

**AYES:**

**NOES:**

**ABSTAIN:**

**ABSENT:**

\_\_\_\_\_  
**CHRIS CANNING, Mayor**

**ATTEST:**

\_\_\_\_\_  
**IRENE CAMACHO-WERBY, City Clerk**



Recreation Equipment

Building Community since 1973

Opportunity Name Webb Memorial Bench  
 Quote Name Webb Memorial Bench  
 Bill To Name Calistoga, City of  
 Bill To 1232 Washington Street  
 Calistoga, California 94515  
 United States

Quote Number 00030165  
 Quote Date 8/15/2019  
 Quote Exp Date 9/16/2019  
 Est Lead Time 5-7 weeks  
 Ship To Name Calistoga, City of  
 Ship To City of Calistoga  
 414 Washington St  
 Calistoga, California 94515  
 United States

Quantity	Product	Product Description	Sales Price	Total Price
1.00	58-60	6' CAST BENCH, STEEL SEAT, black powder coat.	\$1,130.00	\$1,130.00
1.00	PLAQUE METAL	PLAQUE-028843 2" X 10" X 3/8" ZINC ETCHED PLAQUE	\$350.00	\$350.00

Total Quote Amounts

County/ City Tax	Napa County	Materials Amount	\$1,480.00
Tax Rate	7.7500%	Tax Amount	\$114.70
Credit Terms	Net 30 On Materials Shipment	Labor Total	\$0.00
		Freight Amount	\$389.00
		Total	\$1,983.70

Notes to Customer

Thank you for the opportunity to quote your upcoming project. PLEASE NOTE: quote does not include installation, offload, payment and performance bonds, engineering calculations, security, storage, permits, inspection, or safety surfacing unless otherwise noted.

Deposits may be required before order can be placed depending on customer credit terms. Your purchase is subject to the terms and conditions of this quote, approval of this quote agrees to those terms.

If ordering materials after the expiration date, please add 3-6% annually to materials for anticipated price increase. If this is for a BID, it is the responsibility of the General Contractor bidding to adjust their bid to accommodate anticipated pricing. Please also note that sales tax will be based on the current rate at the time of shipping, not order date. Customer will be expected to cover these taxes.

Signature \_\_\_\_\_

Name \_\_\_\_\_

Title \_\_\_\_\_

Date \_\_\_\_\_

Prepared By Jon Bawden  
 Email jonb@rossrec.com

In loving memory  
Marcy Webb  
Loving mother, wife, sister, daughter, friend  
October 13, 1971 - April 27, 2019

- APPROVED
- REJECTED

BY \_\_\_\_\_ DATE \_\_\_\_\_

**2" X 10" PLAQUE**

PLAQUE NOT TO SCALE

INTERNAL USE ONLY  
PLQ ORDERED:  
SO/REP:  
ITEM:  
QTY:  
EST:



PLAQUE-028843A-06

8/16/19

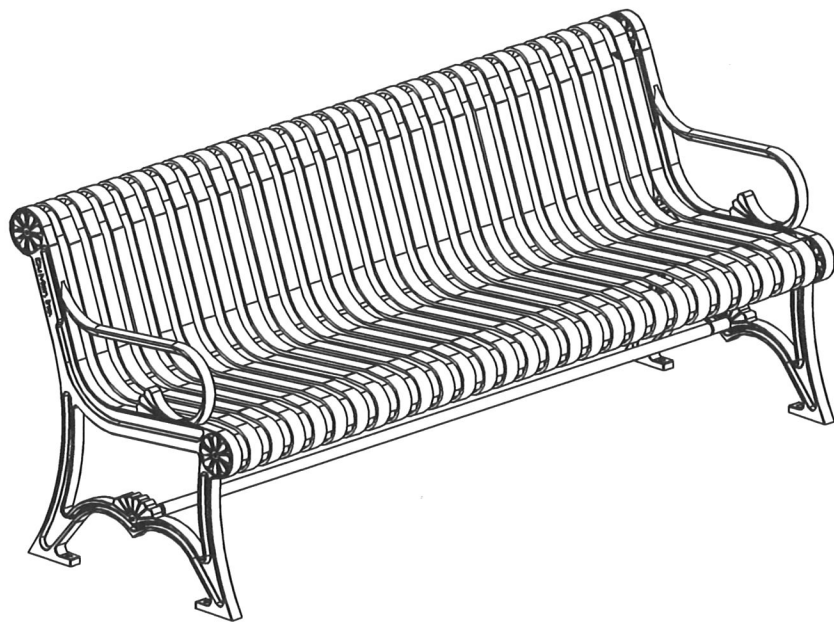
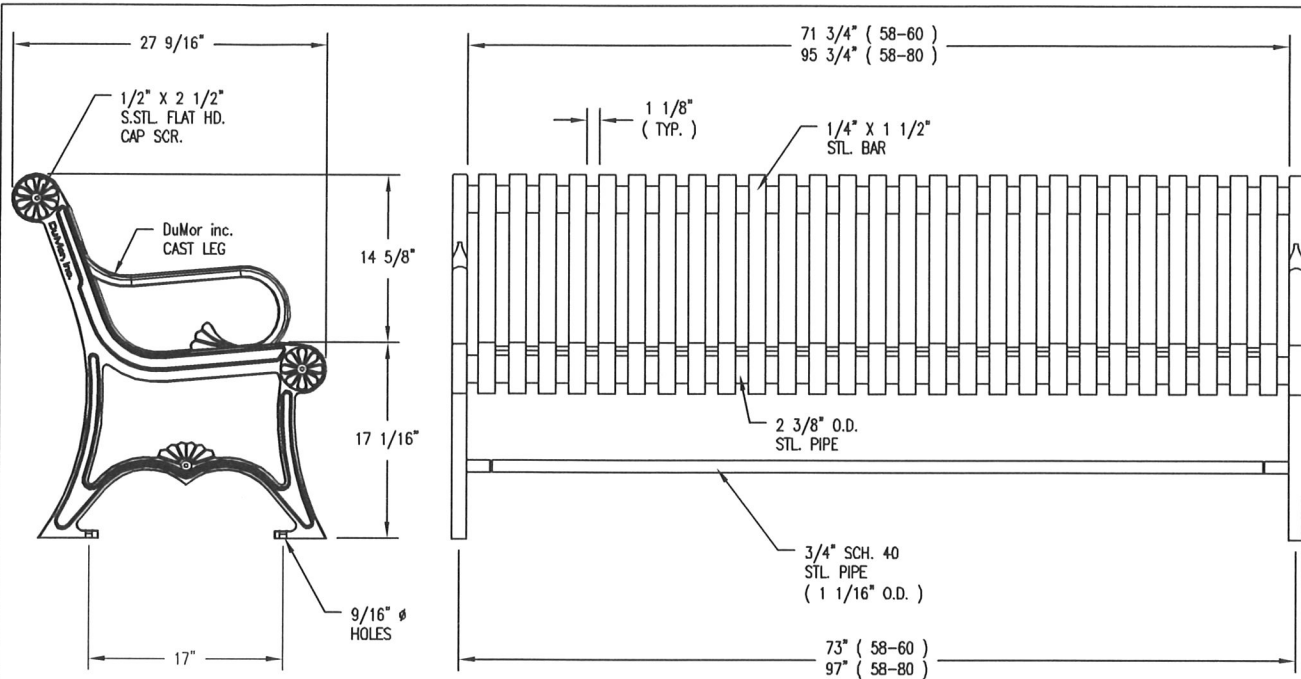

**NOTES**

- 1.) ALL STL. MEMBERS COATED W/ ZINC RICH EPOXY THEN FINISHED W/ POLYESTER POWDER COATING.
- 2.) 1/2" X 3 3/4" EXPANSION ANCHOR BOLTS PROVIDED.
- 3.) CUSTOM LETTERING AVAILABLE FOR RECESSED SIDE PANELS ( TOTAL OF 37 SPACES )

CUSTOM LETTERING ( 37 SPACES )

**LENGTH OPTIONS**

- 6' BENCH
- 8' BENCH



BENCH

DATE DRAWN : 3/22/94  
 DRAWN BY : AH  
 DATE REV. : 11/21/99  
 REV. BY : JSB

REV.  
D

DRAWING NUMBER

58 SERIES

SHEET  
1 OF 2



**NOTES:**

- 1.) DURING ASSEMBLY PROCEDURE;  
DO NOT COMPLETELY TIGHTEN HARDWARE.
- 2.) THE ACTUAL PARTS WILL NOT BE NUMBERED.  
NUMBERS ONLY APPLY TO DRAWING.
- 3.) UPON COMPLETION OF ASSEMBLY SQUARE  
ALL COMPONENTS THEN TIGHTEN ALL HARDWARE.
- 4.) MOUNT AND ANCHOR AS SPECIFIED.

**TOOLS REQ'D**

- 3/4" WRENCH
- 5/16" ALLEN WRENCH
- 1/2" MASONRY DRILL BIT
- DRILL
- RATCHET STRAP (PROVIDED)

**PARTS LIST**

ITEM	QTY	PART NO	DESCRIPTION
1	2	0-57-00-02	CAST IRON BENCH SUPPORT
2	1	0-57-60-04	71 3/4" PIPE BRACE
3	1	0-58-60-01	6' STL SEAT
4	6	1-12-065	1/2" X 2 1/2" FLT SKT HD CAP SCR

**KITS PROVIDED**

ITEM	QTY	PART NO	DESCRIPTION
5	1	K-FC0840-6	1/2" CAP HARDWARE KIT (6PC)
6	1	K-ANC0860-4	1/2" X 3 3/4" SS ANCHOR KIT (4PC)

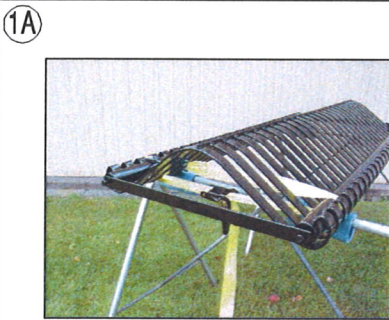
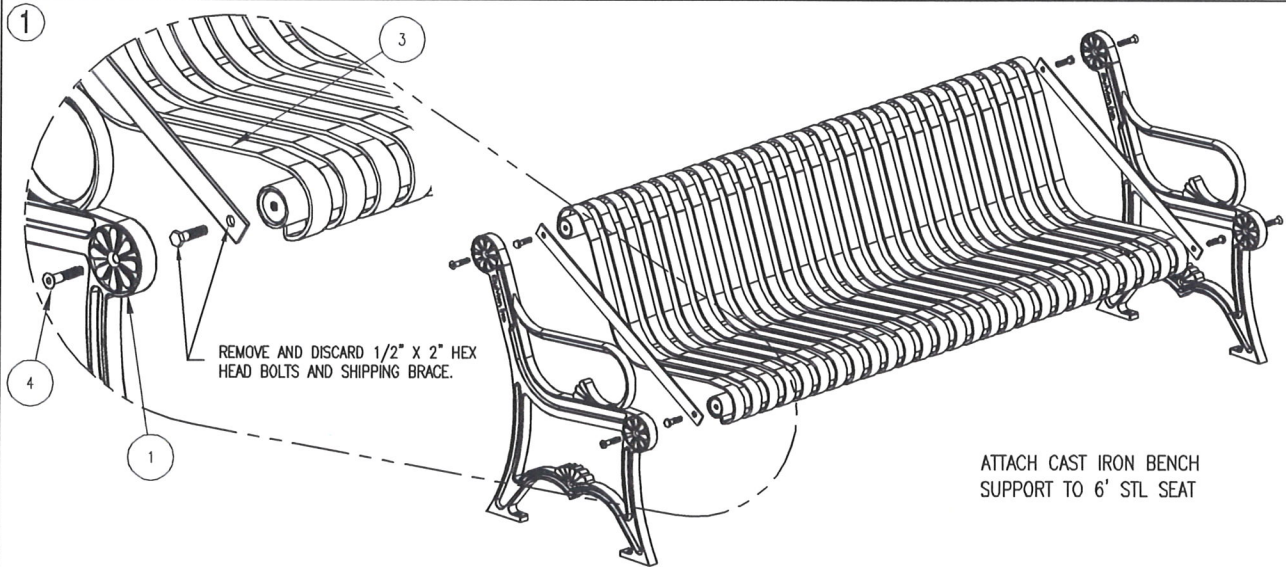

PLACE SEAT ASSEMBLY ON WORK SURFACE ALLOWING ACCESS TO ENDS. PLACE RATCHET STRAP AROUND SEAT ASSEMBLY AS SHOWN ABOVE.

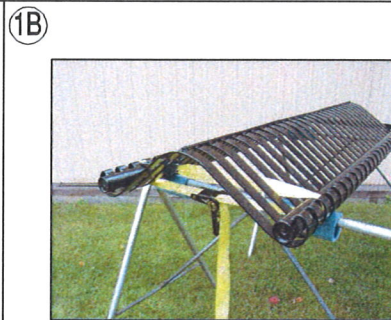

TIGHTEN STRAP UNTIL SHIPPING BRACKET BECOMES LOOSE. THEN REMOVE AND DISCARD BOLTS & SHIPPING BRACKET.

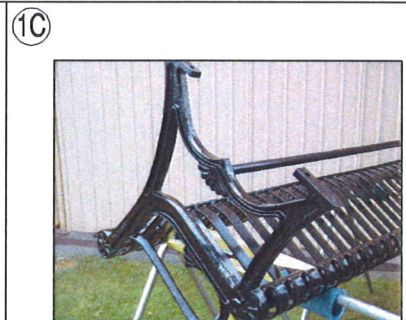

ATTACH CAST SUPPORT TO SEAT ASSEMBLY. IF HOLES IN CASTING DO NOT ALIGN WITH THE SEAT ASSEMBLY, ADJUST BY USING THE RATCHET STRAP.

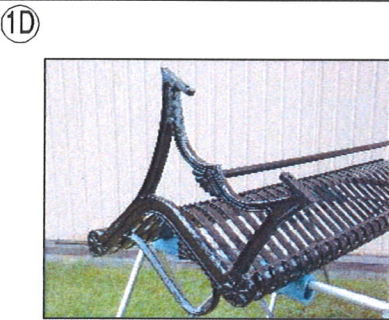

TIGHTEN HARDWARE THEN REMOVE RATCHET STRAP AND REPEAT THIS PROCEDURE ON THE OTHER END OF BENCH.

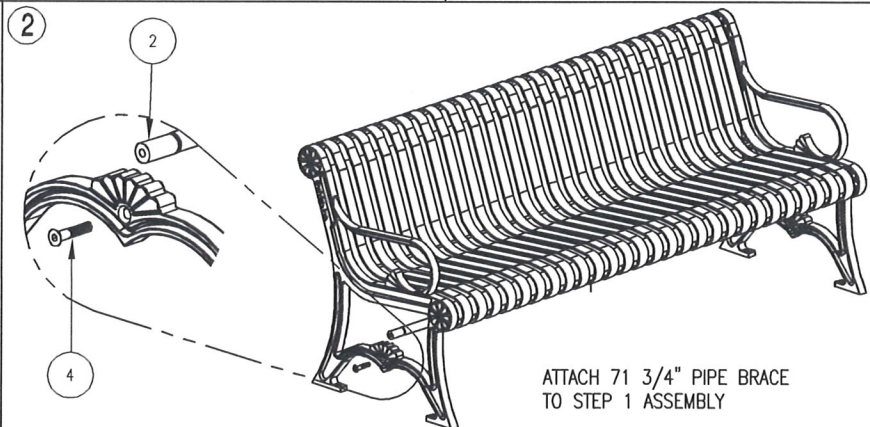

**ASSEMBLY INSTRUCTIONS**

DATE DRAWN : 3/22/94  
 DRAWN BY : AH  
 DATE REV. : 11/21/99  
 REV. BY : JSB

REV.  
D

DRAWING NUMBER

58 SERIES

SHEET  
2 OF 2